

Ruote

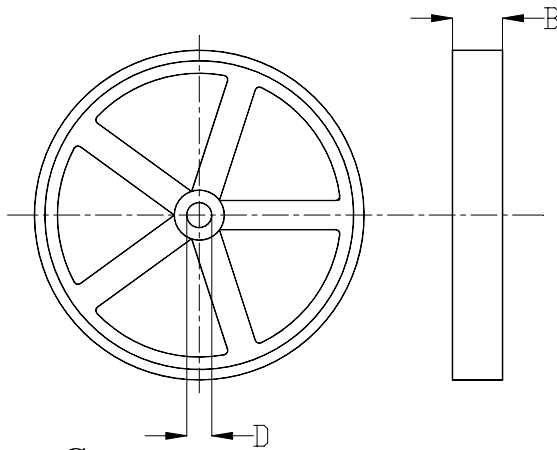

Tipo	Circonferenza	D	B	Copertura
9101	500mm	7-12	25	Gomma liscia
9101.1	500mm	7-12	25	Vulkolan
9102	500mm	7-12	25	Gomma profilata
9103	500mm	7-12	25	Alluminio godronato
9108	200mm	6-8	12	Vulkolan
9109	200mm	6-8	12	Gomma profilata
9110	200mm	6-8	12	Alluminio godronato

SPECIFICARE SEMPRE IL DIAMETRO D INTERNO

Giunti

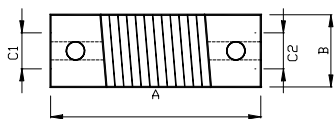

Tipo	Normale		
	A	B	C1/C2
9401	50	26	6-14
9402	35	16	5-8

SPECIFICARE SEMPRE I DIAMETRI C1 E C2

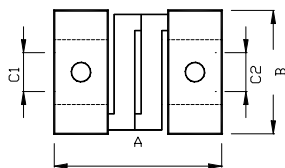

Tipo	Antitorsione		
	A	B	C1/C2
9406	38	25	10-12
9403	26	19	6-8

SPECIFICARE SEMPRE I DIAMETRI C1 E C2

Connettori

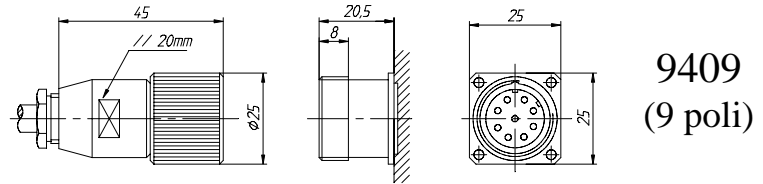

9409
(9 poli)

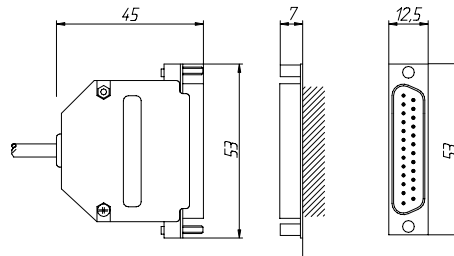

9413
(25 poli)

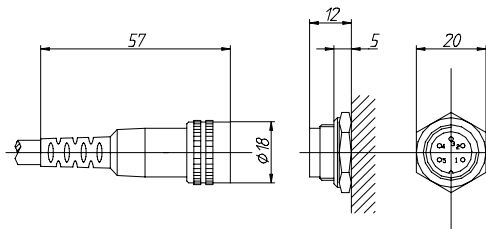

9414
(5 poli)

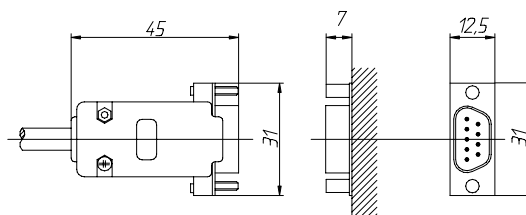

9415
(9 poli)

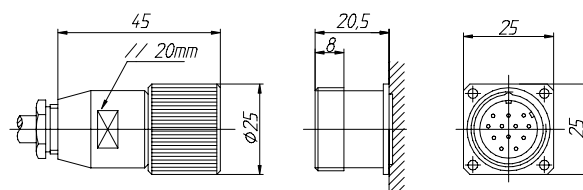

9416
(12 poli)

9418
(7 poli)

9419
(10 poli)

9423
(15 poli)

9426
(16 poli)

9444
(44 poli)

9301 (SPECIFICO PER FLANGE Ø 90)

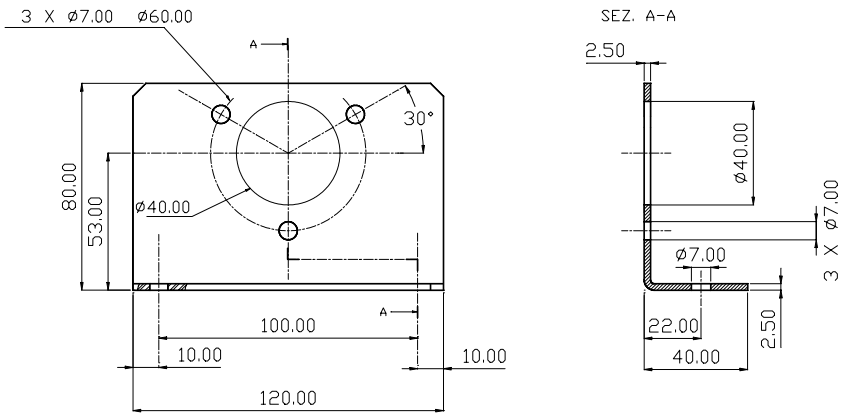

COP58PG

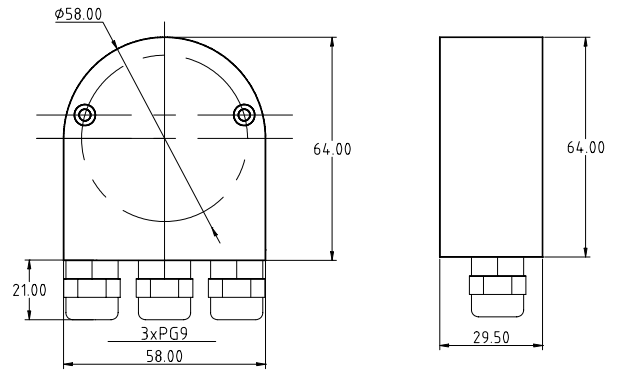

Leva per encoder serie 28
Lev.280

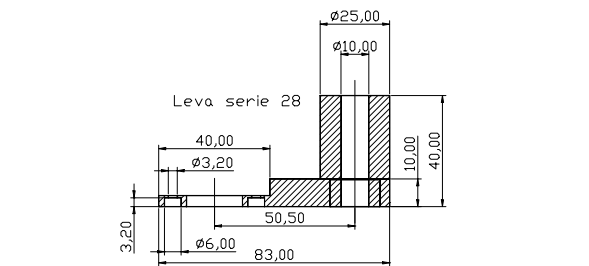

Leva per encoder serie H
Lev.H01

