

HOHNER AUTOMAZIONE SRL

HOHNER HR5000

HI-TECH ELECTRONIC CAM
PROGRAMMER

USER'S MANUAL

VER.3 09/99

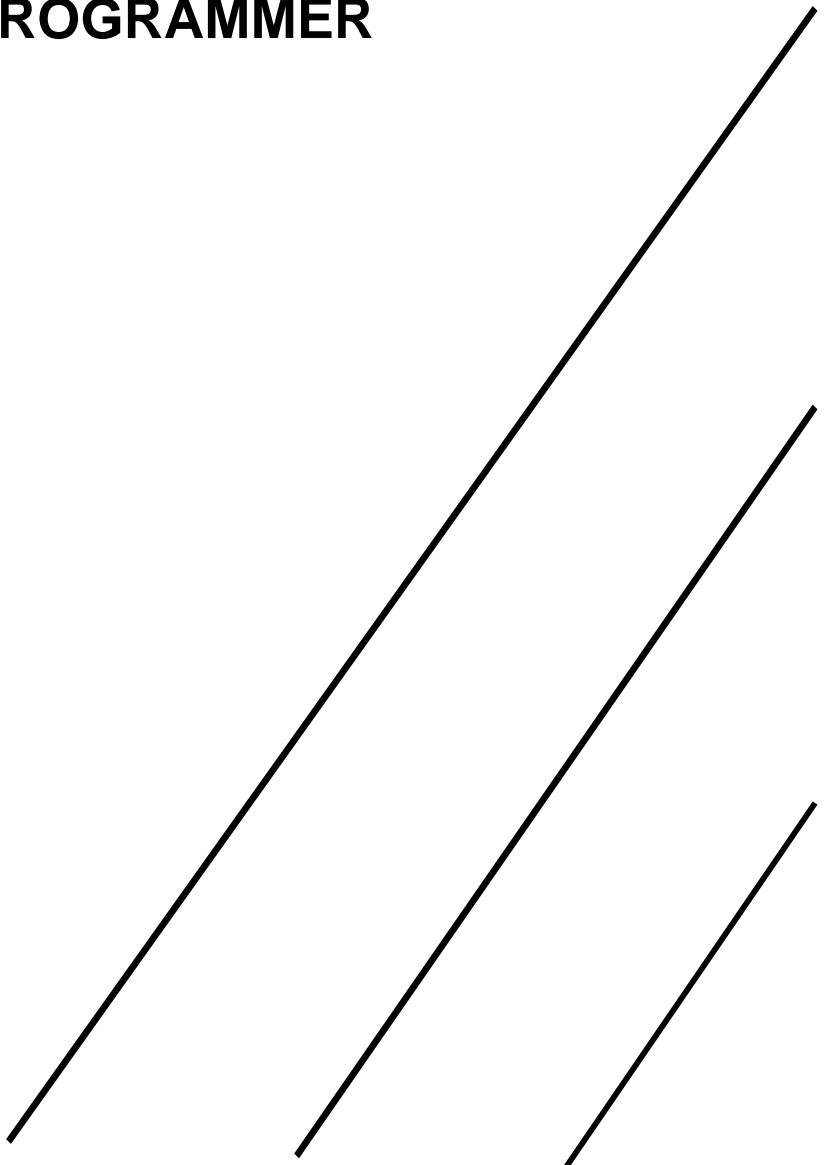

HOHNER HR5000

HOHNER HR5000 programmer allows to pass beyond these traditional problems thanks to its special features, namely:

a software purposely studied to avoid data loss due to wrong programming

This software has been so designed that it can refuse any false entry.

It allows to work and make Real Time changes (changes are made by the machine in real time).

It offers high flexibility: speed up to 900 rpm base offset programming up to 359°, dynamic advance programming up to 3600°, possibility of programming each SINGLE cam degree by degree.

It allows PC interfacing (RS232C) to set all parameters, enter messages and save programs on floppy disk.

Auto-resetting output protections against overloads.

Two displays: work and programming display; display for the description of the cam status, messages, date/time.

Membrane keyboard for a safe use under severe work conditions (dusty environments etc.).

Reduced overall dimension: 140 x 185 x 90 (d x l x h) in compliance with DIN-43700 standards.

INDEX

1. INSTALLATION	5
1.1 POSITIONING	5
1.2 CONNECTIONS.....	5
2. PROGRAM ZERO(0)	6
2.1 MODIFYNG WITH SAFETY	6
2.2 PROGRAMMING	6
2.2.1 <i>Display mode:</i>	7
2.2.2 <i>Cam status modification:</i>	7
2.2.3 <i>End of modify/display operations</i>	9
2.3 HOW TO WORK WITH TEMPORARY MODIFICATIONS.....	10
2.4 HOW TO WORK IN REAL TIME WITH MODIFICATIONS.....	10
2.5 DELETE PROGRAM 0	11
2.6 COPY FROM PROGRAM ZERO TO ANOTHER PROGRAM.	11
2.7 LOCKING/UNLOCKING PROGRAM 0.....	13
3. HOW TO WORK WITH PROGRAM 1-8	14
3.1 WORKING.....	14
3.2 DELETE A PROGRAM	14
3.3 HOW TO COPY A PROGRAM	15
3.4 LOCKING/UNLOCKING A PROGRAM.....	15
3.5 SELECTION OF THE WORK PROGRAM THROUGH THE AUX INPUTS.....	17
4. GENERAL PARAMETERS	18
4.1 DYNAMIC DISPLACEMENT MODIFICATION	18
4.1.1 <i>Dynamic displacement.</i>	18
4.1.2 <i>Cams-Dynamic displacement association</i>	19
4.2 HOW TO SET UP ENCODER PARAMETERS.....	20
4.3 CAM LOCKING	21
4.4 DYNAMIC CONTROL	22
4.4.1 <i>Definition of functioning</i>	22
4.4.2 <i>Dynamic set up</i>	23
4.4.3 <i>Braking deviation</i>	24
5. OTHER FUNCTION	25
5.1 WORK SIMULATOR.....	25
5.2 DATE/TIME	25
5.3 SERIAL CONNECTION TO PC	25
5.3.1 <i>Set up for HR5000 to work in serial connection to PC</i>	26
5.3.2 <i>Cams an programs description insert.</i>	26
5.4 LANGUAGE	26
6. MESSAGE MANAGEMENT	28
6.1 INTRODUCTION.....	28
6.2 DISPLAYING REQUEST OPERTAIONS.....	28
6.3 MESSAGES MENU	28
7. GENERAL PARTICULARS	30
APPENDIX BATERY	31
APPENDIX CONNECTIONS	32-34
APPENDIX PASSWORD	35

1. INSTALLATION

1.1 POSITIONING

Install this device into the control panel and be careful that:

- 1) Clamp must be rigid.
- 2) There must be free space to make connections with easy cables positioning.
- 3) If any, noise sources (i.e. power controls) in control panel must be as far as possible from HR5000.
- 4) Big heat sources must be as far as possible from HR5000.

1.2 CONNECTIONS

Following connectors are positioned on rear panel:

- 1) **I/O AUX:** auxiliary input/output
- 2) **CAMME 1-16:** control output of 1-16 cams
- 3) **CAMME 17-32:** control output of 17-32 cams
- 4) **INGRESSO ENCODER:** encoder data input
- 5) **INGRESSO MESSAGGI:** PLC interface to input user message code to be displayed
- 6) **ALIMENTAZIONE:** input to connect power supply

To connect HR5000, see the connection's sheets.

2. PROGRAM ZERO (0)

2.1 MODIFYING WITH SAFETY

Program zero was studied on purpose to program, modify and verify all the work without to change the stored program.

ALL PROGRAMMING, MODIFICATIONS AND CHECKS CAN BE DONE ONLY INTO PROGRAM ZERO. By this, you can't lose the starting data, you can verify what you are modifying in real time mode, without changing the preceding program, you could work with temporary modifications of a previously stored program that will not change.

2.2 PROGRAMMING

From main menu (dsp1): 1.WORK, 2.PROGRAM MANAGEMENT,
3.GENERAL PARAMETERS, 4.MORE
choose 2nd choice.

Program management menu appears: 1.MODIFY, 2.DELETE,3. COPY, 4.LOCK

Choose 1st choice.

2 menus could appear:

- 1) PROGRAM 0 FULL, CONTINUE? ↓Y ↑N:
there is another program stored into the zero one that was modified previously.
-a- Answer NO (up arrow) to return to the program management menu.
-b- Answer YES (down arrow) to enter the 2nd menu.
- 2) COPY FROM PROGRAM N°. TO PROGRAM 0:
Input the number of program that has to be modified or processed and press "enter":
that program will be copied into zero and open automatically

NOTE:

- A) The menu 1) do not appear if program 0 is empty.
- B) If any program is stored still into 0, the new program that will be copied will overwrite it; to avoid losing data stored in 0, answer NO (up arrow) in menu 1) and copy program 0 into another level (1÷8).
- C) If you want to modify the data still stored in 0 answer YES in 1) menu, input "0" in 2) menu and press "enter" to enter the program.

When you have inputted the number of program to process, menu BASE DISPLACEMENT appears.

Input the necessary base displacement (admitted values: between 1 and 359°).

Press "enter" to update displacement.

Menu CAM N° : appears.

Input the cam number to be modified or select it using arrows keys $\uparrow\downarrow$ (ex..16), then press "enter".

Cam Status menu appears in display mode. Position of machine and cam status appears on display 2.

POS.: 000 \downarrow VISUAL

■□□□□■□■□□■□□□□

NOTE: Current position is marked by \downarrow arrow;
 ■ cam on status □ cam off staus.

2.2.1 Display mode

Input the position to be displayed and press "enter".

It's possible to shift the cam position by using arrows keys $\uparrow\downarrow$:

Starting position:

POS.: 000 \downarrow VISUAL

■□□□□■□■□□■□□□□

\downarrow Right shifting:

POS.: 003 \downarrow VISUAL

□□■□■□□■□■□□□□□□

\uparrow Left shifting

POS.: 001 \downarrow VISUAL

□□□□■□■□□■□■□□□□

NOTE: Shifting will be faster by depressing continuously arrows keys.

AUTO-LEARNING: HR5000 learns and visualizes the real position of the encoder by pressing "*" key

Proceed with instructions explained in the **2.2.3 Section**

2.2.2 Cam status modification

Press "edit" key to advance to modification mode.

EDIT:

Input the starting position for the cam status changing.

- It's possible to modify the position by using arrows keys.
- AUTO-LEARNING: HR5000 inserts and visualizes the real position of the encoder automatically by pressing "*" key.

Press enter.

HR5000 asks the ending position of the cam status changing.

Input the ending position for the cam status changing.

- It's possible to modify the position by using arrows keys.
- AUTO-LEARNING: HR5000 inserts and visualizes the real position of the encoder automatically by pressing "*" key.

Press enter.

HR5000 asks the status (Set) of the cam in the fixed range.

STATUS (Set) 1 = ON
STATUS (Set) 0 = OFF

Input the expected status and press "enter".

At the end of this procedure HR5000 return to display mode.

EDM:

Press twice "edit" key to enter EDM mode.

EDM is an HR5000 function that permits to modify cams status degree by degree.

When the cursor is shifted (by using the arrows ↓↑), cam status will be update ("on" if "EDM=1", "off" if "EDM=0") in all positions touched by the cursor.

Press "1" key to set "EDM=1".

Press "1" key to set "EDM=0".

Use arrows keys to shift the cursor position:

↓ Right shifting
↑ Left shifting

NOTE: Shifting will be faster by depressing continuously arrows keys.

EXAMPLE:

Set cam 16 to on between position 3 and position 13.

POS.: 000 ↓ EDM=0
□□□□□□□□□□□□□□□□

Press arrow ↓ till the cursor arrives in position 3

POS.: 003 ↓ EDM=0
□□□□□□□□□□□□□□□□

Press "edit"

Press "1"

POS.: 003 ↓ EDM=1
□□□□□■□□□□□□□□□□

Press arrow ↓ and keep it down till the cursor arrives in position 13

POS.: 013 ↓ EDM=1
 ■■■■■■□□□□□□□□□□ .

NOTE: Press "enter" key to shift from modify mode to display mode.

2.2.3 End of modify/display operations.

When all the expected operations will be terminated, press "esc" to return to menu: CAM N°: .

Input another cam number and press "enter" if you want to display or change its status.

Press "esc" to return menu BASE DISPLACEMENT.

Input another base displacement to change the preceding if you want, else press "esc".

In accordance with operations executed two menus can appear:

1)The menu COPY FROM PROGRAM N°. TO PROGRAM 0: if you haven't done modifications

If you want, input another number of program that has to be modified, else press "esc"
 program management menu appears, press "esc" to return to main menu.

2)The menu COPY FROM PROGRAM 0 TO PROGRAM N°: if you have done modifications.

Input the number of the program in wich modification data have to be stored and press
 "enter" .3 menu can appear

- A) **PROGRAM MANAGEMENT: the number of the destination program is empty:**
 HR5000 has stored data automatically.
- B) **PROGRAM FULL, CONTINUE? ↓Y ↑N:the number of the destination program
 is taken up by an UNLOCKED program,**

-a- answer YES (down arrow) to stores data in the chosen number of program all
 the same

-HR5000 stores data and return to program management automatically.

NOTE: The resident program will be overwritten!

- b- answer NO (up arrow) to change address for recording;
 - The menu COPY FROM PROGRAM 0 TO PROGRAM N° appears:
 - Input the new address and press "enter".

NOTE:If all address are full anf you can't delete any resident program, save the
 program onto itself into program number 0 and afterwards transfer it
 (after you have free another address)!

- C) The menu: ACCES DENIED, LOCKED PROGRAM: **the number of the destination program is taken up by a LOCKED program**

Press any key to return to menu COPY FROM PROGRAM 0 TO PROGRAM N°:

Input a new address and press "enter".

NOTE: If all addresses are full and you can't delete any resident program, save the program onto itself into program number 0 and afterwards transfer it (after you have free another address)!

NOTE:. If you don't want to save the modifications input 0 at the question COPY FROM PROGRAM 0 TO PROGRAM N°: , HR5000 will delete that modifications when another program will be modified (it will be copied into 0 automatically).

2.3 HOW TO WORK WITH TEMPORARY MODIFICATIONS

Program zero lets you work by using the modifications of a program already stored in another address.

This way of work allows you to verify modifications of the starting program that you have done or to execute temporary working cycles, **WITH NO LOSING OF STARTING DATA.**

Perform procedures as shown in section 2.2 and store the modifications into 0 (input 0 when menu COPY FROM PROGRAM 0 TO PROGRAM N°: appears)

In main menu (dsp1): 1.WORK, 2.PROGRAM MANAGEMENT,
 3.GENERAL PARAMETERS, 4.MORE,
choose 1st choice

Menu PROGRAM N°: appears

Input "0" and press "enter"

Menu working data PR. DSB. POS. SPD. (PR = program, DSB = base displacement, POS = position, SPD = speed) appear, data are referred to the preceding program stored on 0.

Display 2 swows indications of braking deviation (ScFr), Movement Control (CM) and Extra-stroke Control (EC).

2.4 HOW TO WORK IN REAL TIME WITH MODIFICATIONS

Program 0 allows to work and in the same time modify the utilized program, this is to verify the inputted modifications at the moment.

From main menu (dsp1): 1.WORK, 2.PROGRAM MANAGEMENT,
 3.GENERAL PARAMETERS, 4.MORE,
choose 1st choice.

Menu PROGRAM N° : appears

Input "0" and press "enter"

Menu working data PR. DSB. POS. SPD. (PR = program, DSB = base displacement, POS = position, SPD = speed) appear, data are referred to the preceding program stored on 0.

Display 2 swows indications of braking deviation (ScFr), Movement Control (CM) and Extra-stroke Control (EC).

Press twice "esc" to return to main menu.

From main menu (dsp1): 1.WORK, 2.PROGRAM MANAGEMENT,
3.GENERAL PARAMETERS, 4.MORE,
choose 2st choice.

Program management menu appears: 1.MODIFY, 2.DELETE,3. COPY, 4.LOCK

Choose 1st choice.

2 menus could appear:

- 1) PROGRAM 0 FULL, CONTINUE? ↓Y ↑N:
there is another program stored into the zero one thet was modified previously.
-a- Answer NO (up arrow) to return to the program management menu.
-b- Answer YES (down arrow) to enter the 2nd menu.
- 2) COPY FROM PROGRAM N°. TO PROGRAM 0:
Input the number of program that has to be modified or processed and press "enter":
that program will be copied into zero and open automatically

NOTE:

- A) The menu 1) do not appear if program 0 is empty.
- B) If any program is stored still into 0, the new program that will be copied will overwrite it; to avoid losing data stored in 0, answer NO (up arrow) in menu 1) and copy program 0 into another level (1÷8).
- C) If you want to modify the data still stored in 0 answer YES in 1) menu, input "0" in 2) menu and press "enter" to enter the program.

Follow steps indicated in section 2.2 to input the changing requested.

All the written modifications will executed by machinery at the moment!

2.5 DELETE PROGRAM 0

Program 0 is locked. When the modifications executed will be stored in another eddress HR5000 delete data in program 0. Moreover, when you copy data to program zero to do some modifications of it, old data stored in zero will be deleted.

2.6 COPY FROM ZERO TO ANOTHER PROGRAM

Program 0 is locked. You can copy only FROM zero to another program.

NOTE: This operation will delete data stored in zero.

From main menu (dsp1): 1.WORK, 2.PROGRAM MANAGEMENT,
3.GENERAL PARAMETERS, 4.MORE,
choose 2st choice.

Program management menu appears: 1.MODIFY, 2.DELETE,3. COPY, 4.LOCK

Choose 3st choice.

Menu SOURCE PROGRAM:
DESTINATION PROGRAM:
appears

Input "0" (source program) and press "enter"

NOTE: If program 0 is empty menu PROGRAM NOT STORED appears, press any key to
return to menu: SOURCE PROGRAM:
DESTINATION PROGRAM:

Input the number of the destination program and press "enter".

3 menu can appear:

A) PROGRAM MANAGEMENT: **the number of the destination program is empty:**
HR5000 has stored data automatically.

B) PROGRAM FULL, CONTINUE? ↓ Y ↑ N: **the number of the destination program
is taken up by an UNLOCKED program,**

-a- answer YES (down arrow) to stores data in the chosen number of program all
the same

-HR5000 stores data and return to program management
automatically.

NOTE: The resident program will be overwritten!

-b- answer NO (up arrow) to change address for recording;
- The menu SOURCE PROGRAM:
DESTINATION PROGRAM: appears:
- Input the new address and press "enter".

NOTE: If all address are full anf you can't delete any resident program, save
the program onto itself into program number 0 and afterwards transfer
it (after you have free another address)!

C) The menu: ACCES DENIED, LOCKED PROGRAM: **the number of the
destination program is taken up by a LOCKED program**

Press any key to return to menu: SOURCE PROGRAM:
DESTINATION PROGRAM:
input "0" and press "enter"

Input a new destination address and press "enter".

NOTE: If all address are full and you can't delete any resident program, save the program onto itself into number 0 and afterwards transfer it (after you have free another address).

2.7 LOCKING / UNLOCKING PROGRAM 0

Program zero is locked.

It is not possible to Unlock program zero.

3. HOW TO WORK WITH PROGRAM 1-8

3.1 WORKING

From main menu (dsp1): 1.WORK, 2.PROGRAM MANAGEMENT,
3.GENERAL PARAMETERS, 4.MORE,
choose 1st choice.

Menu N.PROGRAM: appears

Input the program number to be used (1÷8) and press "enter".

NOTE: if program is empty display visualizes PROGRAM NOT STORED, press any key to return to menu N.PROGRAM:

The working data menu appears: PR. DSB. POS. SPD. (PR = program, DSB = base displacement, POS = position, SPD = speed); it is related to the chosen program.

Display 2 swows indications of braking deviation (ScFr), Movement Control (CM) and Extra-stroke Control (EC).

3.2 DELETE A PROGRAM

From main menu (dsp1): 1.WORK, 2.PROGRAM MANAGEMENT,
3.GENERAL PARAMETERS, 4.MORE,
choose 2st choice.

Program management menu appears: 1.MODIFY, 2.DELETE,3. COPY, 4.LOCK

choose 2st choice.

Menu PROGRAM NUM. TO BE DELETED: appears

input the number of program you wish to delete and press "enter".

3 menus could appear:

A) ARE YOU SURE? ↓S ↑N; **the number of destination program is taken up by an UNLOCKED program**

-a- Answer YES (down arrow) to delete
- HR5000 deletes data and automatically return to prgram management menu

-b- Answer NO (up arrow) if you are not sure to delete program

- menu PROGRAM NUM. TO BE DELETED appears again:
 - press "esc" to return to main menu

- B) ACCESS DENIED, LOCKED PROGRAM: **the number of destination program is taken up by a LOCKED program**

Press any key to return to menu PROGRAM NUM. TO BE DELETED:

 - a- If you **don't want** to delete program follow instructions below:
 - Press "esc" to return to program management menu
 - Press "esc" to return to main menu

 - b- If you **want** to delete program anyway follow instructions below:
 - Press "esc" to return to program management menu
 - Choose options 4. LOCK and follow instructions in section 3.4
 - When the program is inlocked delete program as shown in this section (3.2)

- C) PROGRAM NOT STORED, press any key to return to menu PROGRAM NUM. TO BE DELETED

3.3 HOW TO COPY A PROGRAM

From main menu (dsp1): 1.WORK, 2.PROGRAM MANAGEMENT,
3.GENERAL PARAMETERS, 4.MORE,
choose 2st choice.

Program management menu appears: 1.MODIFY, 2.DELETE,3. COPY, 4.LOCK
choose 3st choice.

Menu SOURCE PROGRAM:
DESTINATION PROGRAM:
appears

input the number of source program and press "enter".

NOTE: If program is empty menu PROGRAM NOT STORED appear, press any key to
return to menu SOURCE PROGRAM:
DESTINATION PROGRAM:

Input the number of the destination program and press "enter".

3 menu can appear:

- A) PROGRAM MANAGEMENT: **the number of the destination program is empty:**
HR5000 has stored data automatically.

- B) PROGRAM FULL, CONTINUE? ↓Y ↑N:**the number of the destination program is taken up by an UNLOCKED program,**

-a- answer YES (down arrow) to stores data in the chosen number of program all the same

-HR5000 stores data and return to program management automatically.

NOTE: The resident program will be overwritten!

-b- answer NO (up arrow) to change address for recording;

- The menu SOURCE PROGRAM:

DESTINATION PROGRAM: appears:

- Input the new address and press "enter".

NOTE: If all address are full and you can't delete any resident program, free an address before copyng the program (after you have free another address)!

- C) The menu: ACCES DENIED, LOCKED PROGRAM: **the number of the destination program is taken up by a LOCKED program**

Press any key to return to menu: SOURCE PROGRAM:

DESTINATION PROGRAM:

input the number of source program and press "enter"

Input a new destination address and press "enter".

NOTE: If all address are full and you can't delete any resident program, free an address before copyng the program (after you have free another address)!

3.4 LOCKING / UNLOCKING A PROGRAM

Locking a program may be useful to not overwrite it casually by a copy for example

From main menu (dsp1): 1.WORK, 2.PROGRAM MANAGEMENT,
3.GENERAL PARAMETERS, 4.MORE,

choose 2st choice.

Program management menu appears: 1.MODIFY, 2.DELETE,3. COPY, 4.LOCK

choose 4st choice.

Menu: INPUT
PASSWORD <---->

appears

NOTE:

- a- If you input zero to dynamic displacement HR5000 return automatically to dynamic displacement menu
- b- Maz useful speed is a function of the working load: in best condition is 900 rpm
- c- You can input 900 rpm of maz speed, this to have the best precision if you don't know exactly the real max. speed.

Input the degrees (3 digits) in accordance to the stored max. speed and press "enter"

NOTE: Max Degrees: 3600°

Menu DYNAMIC DISPLACEMENT
1.A 2.B 3.C 4.D

appears again

If needed, choose a new dynamic displacement and repeat preceding operations, else press "esc" to return to general parameters menu.

ATTENTION: Straight line of dynamic displacement A is the reference to extra-stroke control (EC)

Press "esc" to return to main menu

4.1.2 Cams-Dynamic displacement association

Every cam may be associate to one of 4 dynamic displacements .

From main menu (dsp1): 1.WORK, 2.PROGRAM MANAGEMENT,
3.GENERAL PARAMETERS, 4.MORE,
choose 3st choice.

Menu of general parameters: 1.DYNAMIC DISPLACEMENT, 2.ENCODER
3.CAM LOCKING, 4.DYNAMIC CONTROL

choose 1st choice.

Menu: 1. MODIFY DYNAMIC DISPLACEMENT
2. CAMS-DISPLACEMENT ASSOCIATION

Choose 2rd choice

Menu: N. CAM : 01
0 0 0 0 0 0 0 0

It's possible to press:

- 0 : cam not associated
- 1 : cam associated to dynamic displacement A
- 2 : cam associated to dynamic displacement B
- 3 : cam associated to dynamic displacement C
- 4 : cam associated to dynamic displacement D

To shift to the cam number wanted use arrows key:

⇩ shift right
⇧ shift left

EXAMPLE:

Initial position: N. CAM : 01
0 0 0 0 0 0 0 0
 to associate dynamic displacement C to cam 01, press 3:
 N. CAM : 01
3 0 0 0 0 0 0 0
 shift right, press key ⇩:
 N. CAM : 08
 3 0 0 0 0 0 0 0
 to associate dynamic displacement D to cam 08, press 4:
 N. CAMMA : 08
 3 0 0 0 0 0 0 4

shift left, press key ⇧:

N. CAMMA : 07
 3 0 0 0 0 0 0 4
 to associate dynamic displacement A to cam 07, press 4:
 N. CAMMA : 07
 3 0 0 0 0 0 1 4.

Press "esc" to return to dynamic displacement menu

Press "esc" to return to general parameters menu

P

ress "esc" to return to main menu

4.2 HOW TO SET UP ENCODER PARAMETERS

HOHNER HR5000 was projected to be connected to any hohner absolute encoder.

To set up the programmer in accordance with used encoder, follow next operations.

NOTE: Encoder parameter could be extracted from code on the cover label of encoder.

From main menu (dsp1): 1.WORK, 2.PROGRAM MANAGEMENT,
 3.GENERAL PARAMETERS, 4.MORE,
 choose 3st choice.

Menu of general parameters: 1.DYNAMIC DISPLACEMENT, 2.ENCODER
 3.CAM LOCKING, 4.DYNAMIC CONTROL
 choose 2st choice.

Menu : 1. ENCODER DATA
 2. UP/DOWN DIRECTION

Choose option 1 to change encoder data

Menu: ENCODER DATA
 NPN_PNP:

Input code of the used encoder:

Encoder code (output data encoder code) could be of 4 different types:

GRAY	input "0"
BINARY	input "1"
GRAY EXCESS	input "2"
BCD	input "3"

Press "enter".

Choose the output circuits of encoder	NPN	input "0"
	PNP	input "1"

NOTE: If the output circuit of the encoder is LINE DRIVER or PUSH-PULL type, choose option PNP (input 1)

Press "enter"

HR5000 returns to general parameters menu:

1.DYNAMIC DISPLACEMENT, 2.ENCODER,
3.CAM LOCKING, 4.DYNAMIC CONTROL

Press "esc2 to return to main menu.

Choose option 2 to change increment direction

Menu: 1. UP 2.DOWN
DIRECTION: _

Choose the necessary option.

4.3 CAM LOCKING

From main menu (dsp1): 1.WORK, 2.PROGRAM MANAGEMENT,
3.GENERAL PARAMETERS, 4.MORE,
choose 3st choice.

Menu of general parameters: 1.DYNAMIC DISPLACEMENT, 2.ENCODER
3.CAM LOCKING, 4.DYNAMIC CONTROL
choose 3st choice.

Menu: INPUT
PASSWORD <---->

Insert the password.If password is right menu of locking/unlocking cams appears.

CAM: 01
0111100001110001

If cam is LOCKED the symbol is "1"
If cam is "UNLOCKED" the symbol is "0", cursor

To shift to the cam number wanted use arrows keys ↑↓:

EXEMPLE: Initial position: CAMMA: 01
0111100001110001

⇩ Right shifting CAMMA: 08
 0111100001110001

⇧ Left shifting CAMMA: 07
 0111100001110001

Press "1" to **lock** the highlight cam.

Press "0" to **unlock** the highlight cam.

When all the expected operations will be terminated, press "esc" to return to general parameters menu: 1.DYNAMIC DISPLACEMENT, 2.ENCODER, 3.LOCKING, 4.DYNAMIC CONTROL.

Press "esc" to return to main menu.

4.4 DYNAMIC CONTROL

4.4.1 Definition of functioning

HR5000 works with 2 controls of encoder dynamic status that visualizes on display 2.

CM (Movement Control): it controls that encoder is really moving, after machine is already working (and after the initial acceleration).

EC (Extra-stroke Control): when machine stops, EC controls that encoder doesn't go out of acceptable limits.

- N.B. 1) EC works only in encoder incremental direction
 2) To restore the signals of EC and MC press "esc".

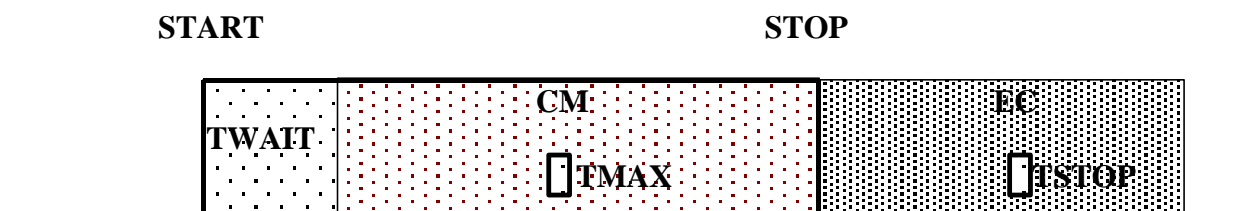

DEFINTIONS:

TWAIT:Is the time in wich HR5000 waits before executing CM control.By this, encoder can accelerate to right speed because HR5000 isn't eneble senses encoder movement.

TMAX: Is the higher gap of time between 2 subsequent position of encoder. It is useful to know if encoder is still moving. If the real gap exceeds this constant, HR5000 see the encoder standing still so displays the CM error on dsp2.

TSTOP: Is the higher gap of time between 2 subsequent position of encoder in extra-stroke space, it is useful to know if encoder really stopped. If the real gap exceeds this constant, HR5000 see the encoder standing still.

MAXDEG:Maximum rotation that encoder can do after the machine was stopped: when exceeded this constant, HR5000 displays EC error on dsp2.

4.4.2 Dynamic set up.

From main menu (dsp1): 1.WORK, 2.PROGRAM MANAGEMENT,
3.GENERAL PARAMETERS, 4.MORE,
choose 3st choice.

Menu of general parameters: 1.DYNAMIC DISPLACEMENT, 2.ENCODER
3.CAM LOCKING, 4.DYNAMIC CONTROL
appears

choose 4st choice.

Menu Twait:
 Tmax:

appears to control CM

Set up Twait time (milliseconds, min 10, max 2550) to start CM after a gap of time machine start.

Press "enter"

Set up Tmax time (milliseconds, min 10, max 2550) to control movement of encoder.

If the real gap exceeds this constant, HR5000 see the encoder standing still so displays on dsp2 the CM error and changes signal status on CM pin of I/O AUX connector.

Press "enter"

Menu Tstop:
 MaxDeg:

appears to control EC.

Set up Tstop time (milliseconds, min 10, max 2550) to verify if encoder stops.

Press "enter"

Input max. degrees for extra-stroke and press "enter".

NOTE: When exceeded this constant, HR5000 displays EC error on dsp2 and change signal status on EC pin of I/O AUX connector.

4.4.3 Braking deviation

Braking deviation is the space between the machine switching off point (START signal low) and point that for HR5000 encoder is stopped (Itjudges by Tstop constant).

This parameter (SCFR) is visualized on display 2 (dsp2) when HR5000 is an working mode.

To the value of SCFR is added the dynamic displacement A.

5. OTHER FUNCTION

5.1 WORK SIMULATOR

This cam programmer has a built in function to operate without any encoder.

From main menu (dsp1): 1.WORK, 2.PROGRAM MANAGEMENT,
3.GENERAL PARAMETERS, 4.MORE,
choose 1st choice.

Menu N. PROGRAM: appears

Input the program number to be used (1÷8) and press "enter".

NOTE: if program is empty display visualizes PROGRAM NOT STORED, press any key to return to menu N. PROGRAM:

The working data menu appears: PR. DSB. POS. SPD. (PR = program, DSB = base displacement, POS= position, SPD = speed); it is related to the chosen program.

Press "esc" 2 times to return to main menu.

Choose 4 th choice.

Menu of more choices appears: 1.SIMULATION 2.DATE/TIME
3.RS232C 4.COUNTRY

Choose 1 th choice.

Every time you press "enter" you will shift from simulation "on" to "off" and vice versa.

Press "esc" to return to previous menu.

5.2 DATE/TIME

From main menu (dsp1): 1.WORK, 2.PROGRAM MANAGEMENT,
3.GENERAL PARAMETERS, 4.MORE,
choose 4st choice.

Menu of more choices appears: 1.SIMULATION 2.DATE/TIME
3.RS232C 4.COUNTRY

Choose 2 th choice.

Menu

DATE: XX/XX d/m
TIME: YY/YY h/m

appears

Insert: day (d) - month (m) - hour (h) - minutes (m), press "enter" after every insertion.

5.3 SERIAL CONNECTIONS TO PC

5.3.1 SET UP OF HR5000 TO WORK IN SERIAL CONNECTION TO PC

From main menu (dsp1): 1.WORK, 2.PROGRAM MANAGEMENT,
3.GENERAL PARAMETERS, 4.MORE

Choose 4th choice.

Menu of more choices appears: 1.SIMULATION 2.DATE/TIME
3.RS232C 4.COUNTRY

Choose 3th choice.Hr5000 displays message "WAITING CONNECTION" on display 1.

Start interfacing program on PC. HR5000 displays message "CONNECTED" on display 1.

NOTE: Press "Esc" on HR5000 to stop the communication in any moment.

At the and of working close PC program. HR5000 display message "WAITING CONNECTION" on display1.

Press "esc" on HR5000 to return to More choices menu.

Press "esc" to return to main menu.

5.3.2 CAMS AND PROGRAMS DESCRIPTION INSERT

Connect HR5000 to PC as show in 5.3.1 section

Insert description by following operations in PC program.

Every time you choose a program HR5000 will visualize its description on display 2.

5.4 LANGUAGE

From main menu (dsp1): 1.WORK, 2.PROGRAM MANAGEMENT,
3.GENERAL PARAMETERS, 4.MORE

Choose 4th choice.

Menu of more choices appears: 1.SIMULATION 2.DATE/TIME
3.RS232C 4.COUNTRY

Choose 4th choice.

Menu

1.I 2.GB 3.D
4.F 5.E

appears

Choose

1. ITALIAN
2. ENGLISH
3. GERMAN
4. FRENCH
5. SPANISH

press "enter"

Press "esc" on HR5000 to return to More choices menu.

Press "esc" to return to main menu.

6. MESSAGE MANAGEMENT

6.1 INTRODUCTION:

HR5000 allow to insert 127 messages by using a serial input connected to PC
To connect HR5000 to PC see 5.3 section (SERIAL CONNECTION TO PC).

Messages send are stored in RAM memory (using floating battery) and can be visualized by a request arriving from Input Messages connector.

All recalled messages stay in *display memory* area till they are deleted by using keyboard.

When a stored message is recalled, HR5000 visualizes it on dsp2 and give to it the receiving ordering number (temporal ordering).

Every time there is a displaying request all functions shown on dsp2 are disabled.

6.2 DISPLAYING REQUEST OPERATIONS

Message number must be a binary code on pins D0-D6 Input Message connector:

HR5000 will read the set up message number and visualize that message on dsp2 by sending strobe signal on pin D7.

NOTE: If a recalled message is already stored in *display memory* area, HR5000 will update the receiving message number.

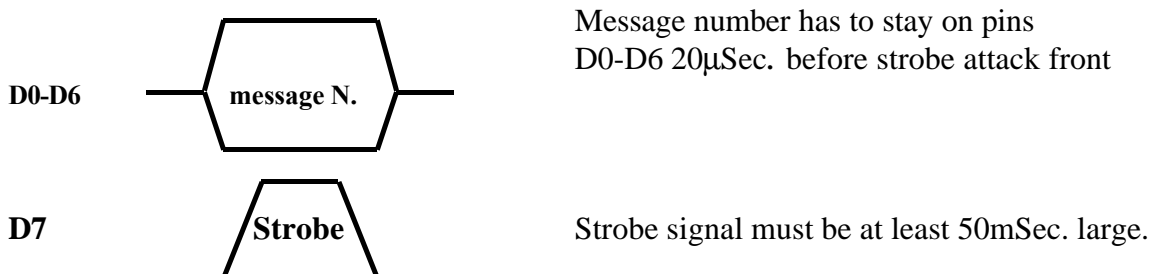

6.3 MESSAGES MENU

Keep key "*" depressed 2 seconds or more to enter messages management menu:

↑P ↓S 0.DEL MESSAGE
RECEIVING MESSAGE N.

Press ↑ arrow key to scroll to Previous message.

Press ↓ arrow key to scroll to Next message.

Press "0" key to delete from *display memory* area message actually displayed.

On display 2 HR5000 visualizes messages of number on display 1.

7. GENERAL PARTICULARS

POWER SUPPLY	24 Vac (options 220 Vac)
CONSUMPTION	10 VA
CAMS STATIC OUTPUT	N° 16/32, 24Vdc-400mA, (Single Total cams: 4A) optocoupled; external supply.
ENCODER INPUT	Optocoupled input for 360 positions/rev. Internal encoder's power supply 24Vdc 300mA. AVAILABLE CODES: Gray, Gray Binary, BCD. Encoder Electronics: All configurations with 24Vdc permitted
AUXILIARY INPUT/ (OUTPUT)	Input/(output) optocoupled 24Vac(dc) for functions; external supply.
MESSAGES INPUT	Optocoupled input to interface PLC; external supply 24Vac/dc
DISPLAY	2 Backlighting LCD, 12 characters x 2 lines
KEYBOARD	16 Keys, anti-abrasive panel, polycarbonate made
INTERFACING	RS232C
BATTERY CHARGE LIFE	6 years
PROGRAMS	8 available + 1 (0) for editing/temporary modifications/real time
VISUALIZING DURING WORK	DSP1: directed degrees, base displacement,speed, Work program N. DSP2: cams status
BASE DISPLACEMENT	Settable from 0 to 359°
DYNAMIC DISPLACEMENT	Settable from 0 to 3600°
SPEED	Max. settable: 900rev/min.

*** LITHIUM BATTERY ***

The HR5000 programmer is supplied with a 3.6 Volt - Size AA battery housed in its rear compartment.

To get maximum reliability, replace the battery every 6 years.
Check the battery installation date on the lid of the HR5000 programmer.

WARNING:

No data are lost if you change the battery when the HR5000 programmer is on.

Should the battery be replaced when the HR5000 programmer is off, the following message will be displayed when switching the programmer on:

“Attention: Ram data lost”

You will need to enter the working parameters again.

This operation will not cause any damage to the system software anyway and the equipment will run regularly.

CABLE FOR SERIAL CONNECTION

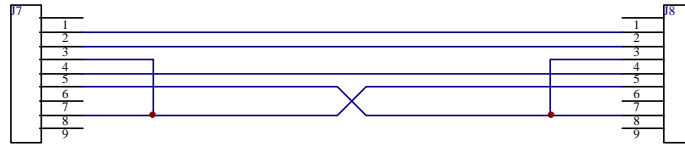

9 POLE TANK CONNECTOR

9 POLE TANK CONNECTOR

LENGHT MAX 15 m.

Connect only when equipment is off

Use a shielded cable, connecting the screen to pin 5 on one side only

CABLE FOR SERIAL CONNECTION

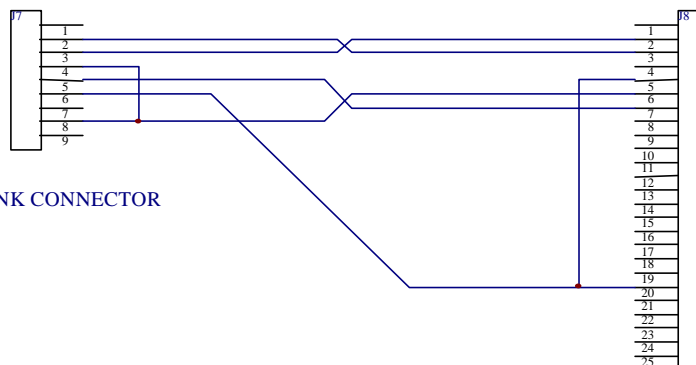

9 POLE TANK CONNECTOR

25 POLE TANK CONNECTOR

LENGHT MAX 15 m.

Connect only when equipment is off

Hohner Automazione s.r.l.

Serial connection

Data: 17-12-96 File HR5CONN2

J4 15pole tank connector

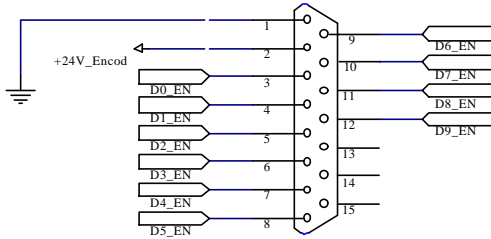

15pole connector m.

ENCODER

+24V_Encoder/GND

Internal power supply for ENCODER

24Vdc 300mA MAX

D0_ENC...D9ENC

ENCODER inputs (6mA for channel)

J5 15pole tank connector

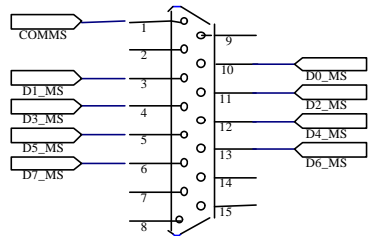

15pole connector f.

MESSAGES

COMMSG

Common , positiv or negative, power supply

D0_MSG...D7_MSG

Inputs from PLC (24Vdc / 6mA for channel)

D0_MSG...D7_MSG:

Display messages inputs bits

J6 9pole tank connector

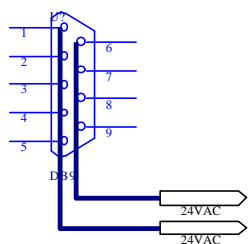

9pole connector f.

Power supply

24 Vac 0.5A

HR5000 power supply

Hohner Automazione s.r.l.
 Connections I/O
 Data: 17-12-96 File HR5CONN1

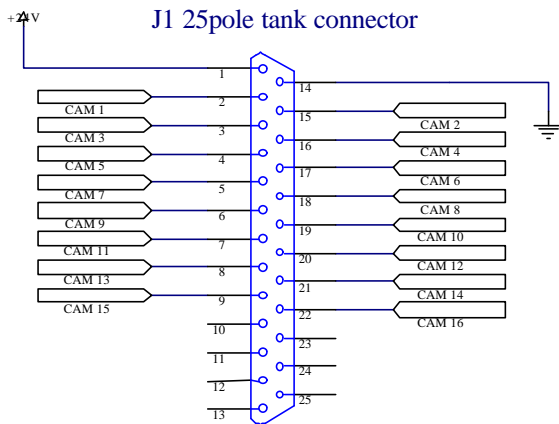

25pole connector f.

CAM 1-16

+24V/GND:

External power supply cam

CAM 1...CAM 16

Outputs cam 24Vdc 400mA

Electronic protection with automatic reset

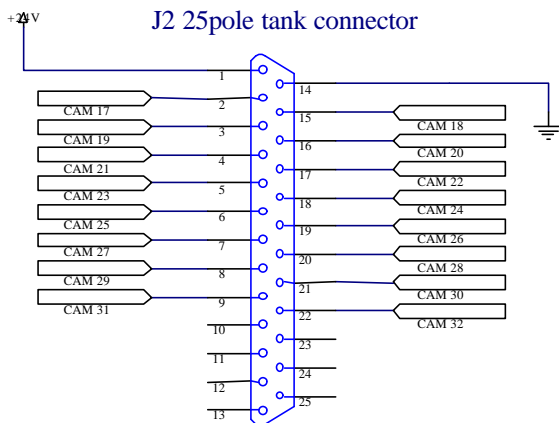

25pole connector f.

CAM 17-32

+24V/GND:

External power supply cam

CAM 17...CAM 32

Outputs cam 24Vdc 400mA

Electronic protection with automatic reset

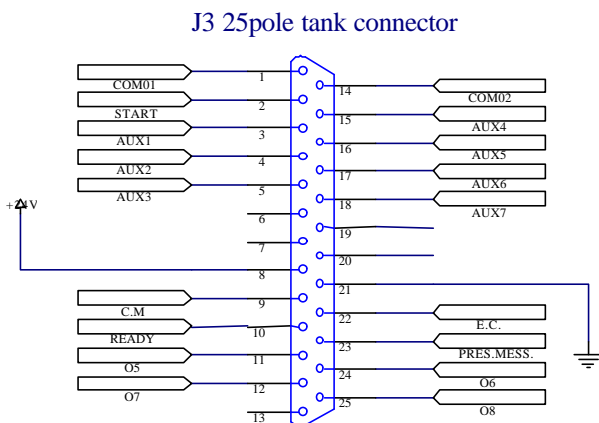

25pole connector f.

I/O AUX

+24V/GND:

Outputs AUX external power supply

COM01

Common inputs: START - AUX1..AUX3

COM02

Common inputs: AUX4...AUX7

Hohner Automazione s.r.l.
 Conessioni CAMME - I/O AUX
 Data: 17-12-96 File HR5CONN

PASSWORD

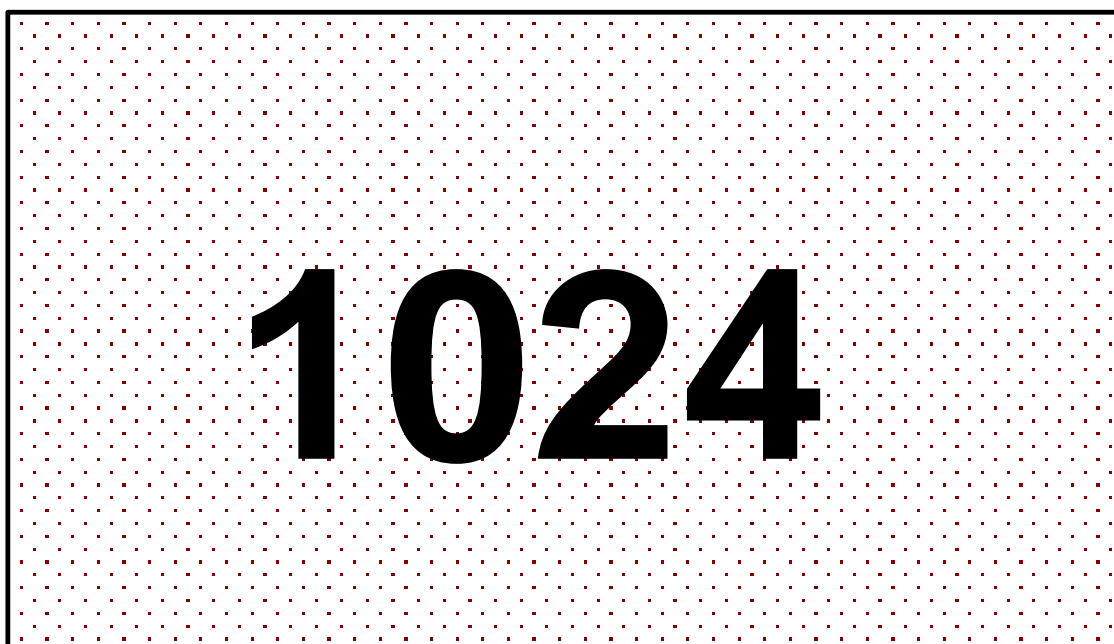

HOHNER AUTOMAZIONE SRL

**PIAZZALE COCCHI, 10 21040 VEDANO OLONA (VA) -
TEL. +039 0332 866109 - FAX +03**

9 0332 866066

<http://www.hohner.it> e-mail:hohner.info@hohner.it