

BSP
BSC

Incremental hollow and blind hollow shaft encoder
ø58mm

Mechanics data

- Cover:** Aluminium
- Body:** Aluminium
- Shaft:** Stainless steel
- Bearings:** 2 a sfere /2 ballraces
- Weight:** 300gr.
- IP protection:** IP65 Shaft side and cable output versions
(for connector output please ask Hohner)
- RPM:** 6000 Max
- Torque:** 5Ncm
- Inertia:** 100gcm²
- Shaft Load:** Axi. 50N - Rad 50N

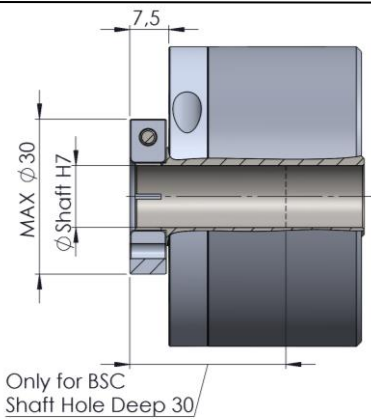

Shaft *M

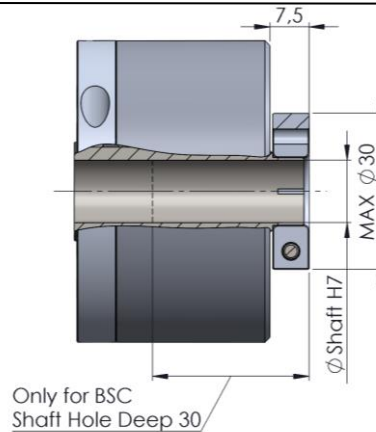

Shaft *L

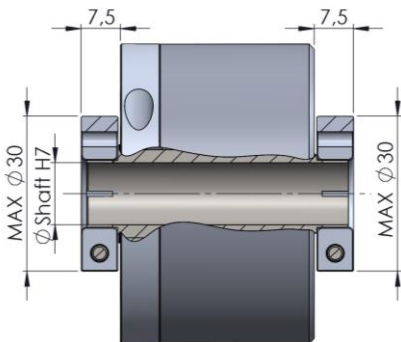

Shaft *P

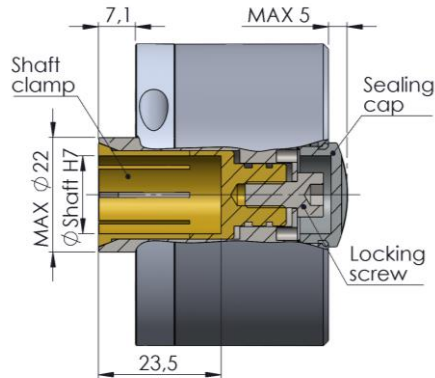

Shaft *T

Flange 1

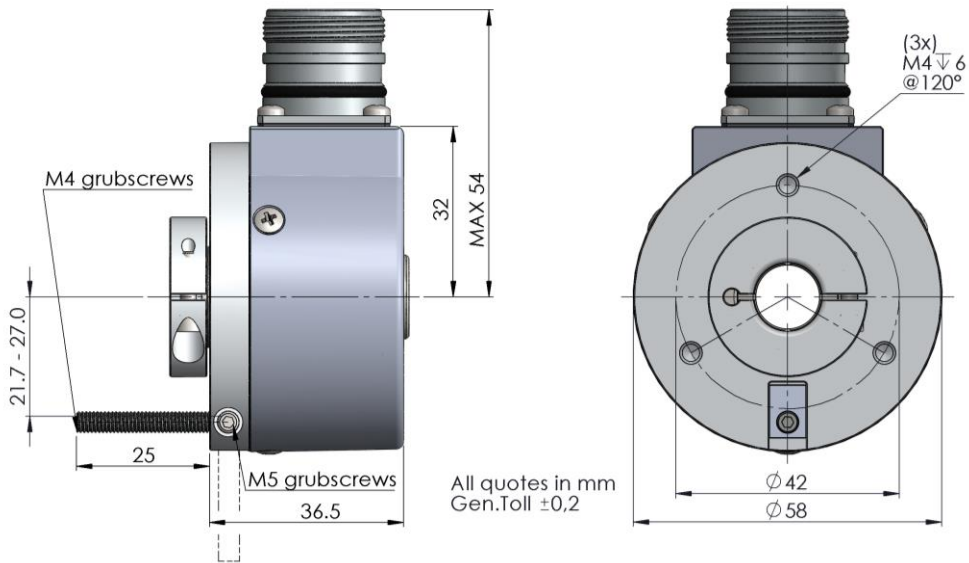

Flange 2

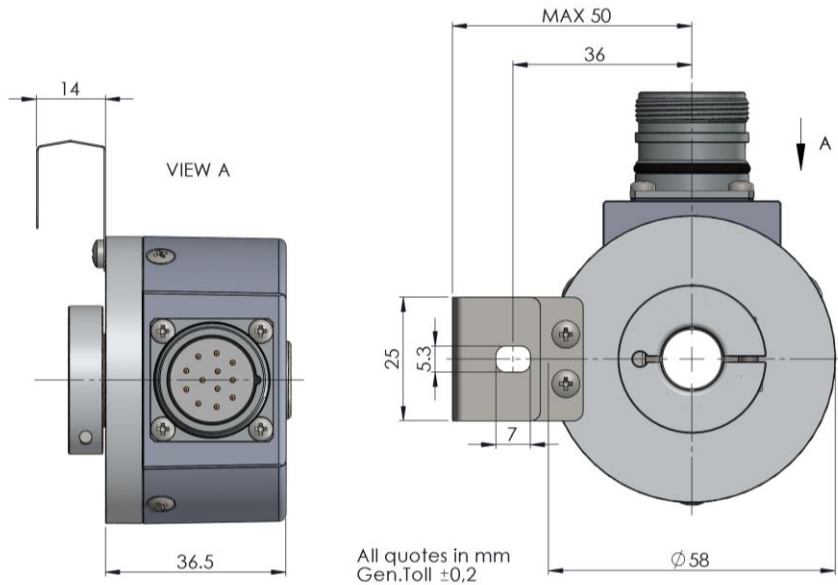

Flange 3

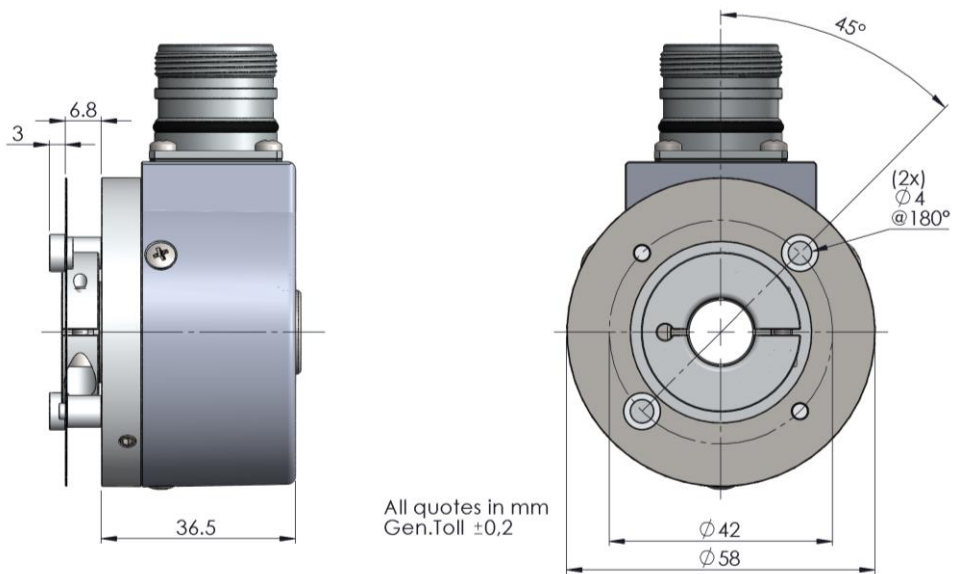

Flange 4

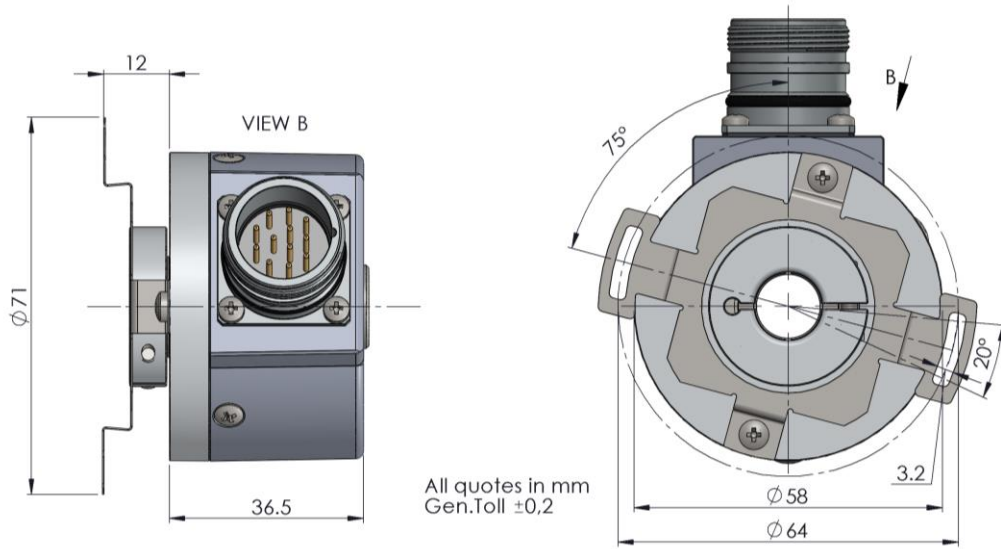

Flange 5

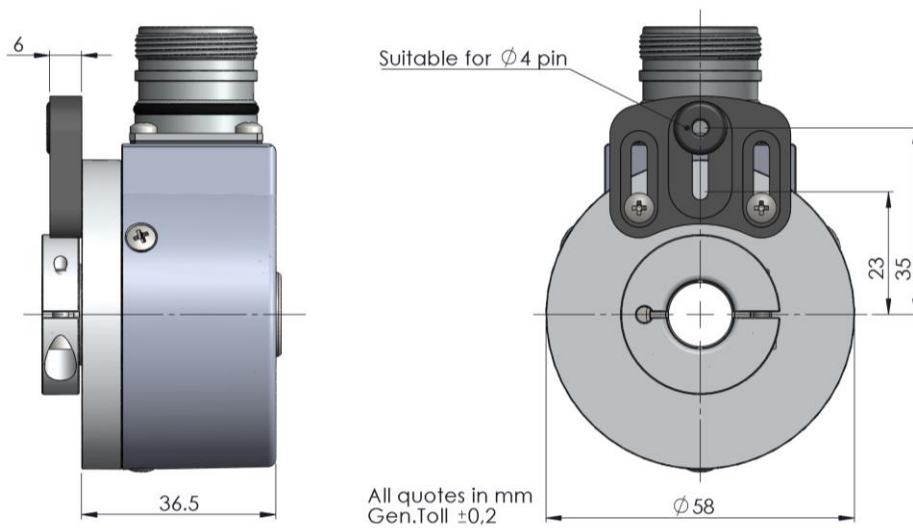

Flange 6

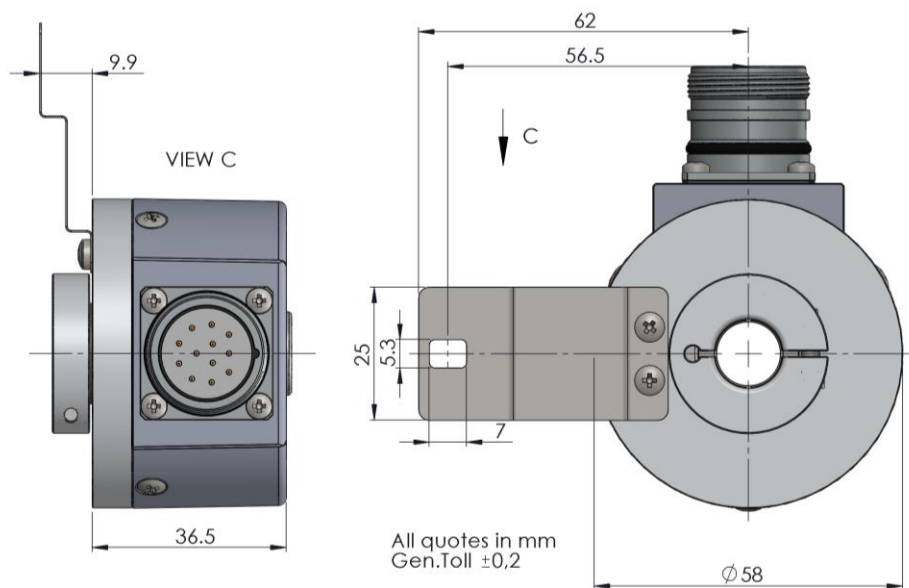

Flange 7

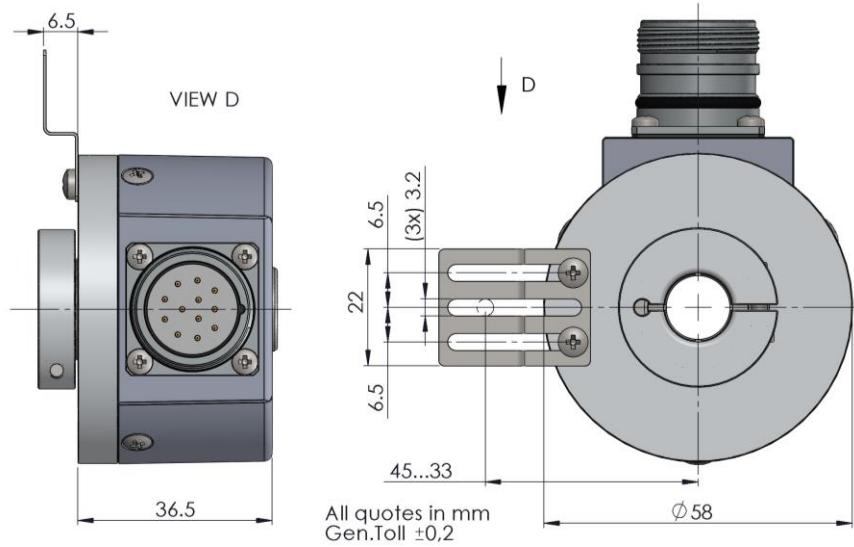

Flange 8

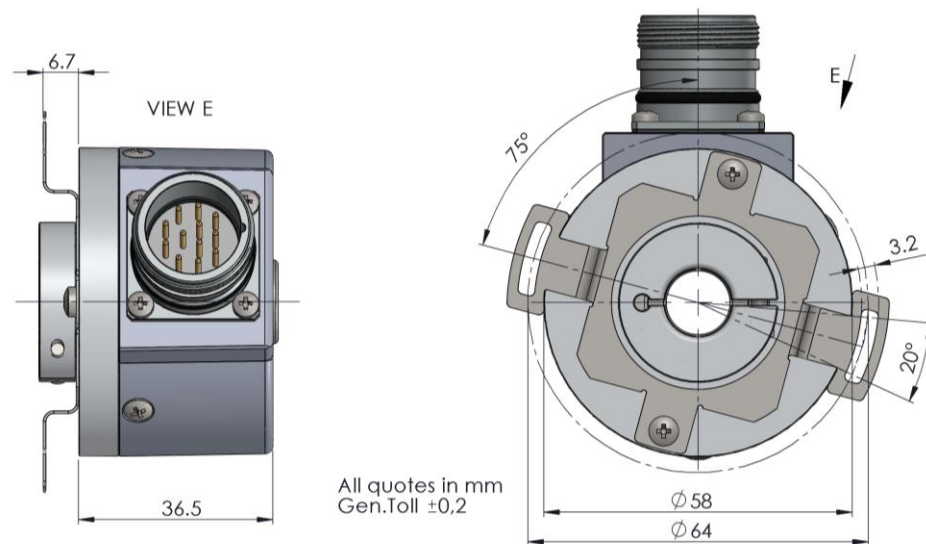

BSP/BSC

Output Signals

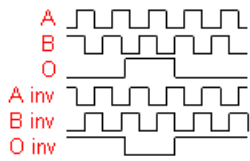

Electronics Data

Power Supply:	5/28 Volt depends on the electronics circuit
Current consumption:	40/80mA depends on the electronics circuit
Load:	40mA
Frequency:	Up to 300KHz depends on the electronics circuit
Protections:	Against short circuit, reversal polarity
Operating Temp:	-20/+70°C

Ordering code

BS*	*	*	*	*	**	/	*/*
Model	Shaft (mm)	Flange	Output	Connections	Option		Resolution
BSP Hollow shaft	Frontal clamp 8M= Ø 08mm 0M= Ø 10mm 2M= Ø 12mm	1 = 2 = 3 = 4 =	2 = AB PP11/28V 3 = AB $\bar{0}$ PP11/28V N = AB+AB $\bar{0}$ PP11/28V	DIN 5P 2 = 9414 Rad	0 = None 1 = High zero pulse Z = Zero gated 180° to A W= Zero gated 90° to AB A = Special connections Y = Power supply 5/12V for NPN/OC/PP U = Power supply 5/30V for outputs PP **		Max 65536
BSC Blind Hollow Shaft	4M= Ø 14mm 1M= Ø 15mm Rear Clamp 2L= Ø 12mm 4L= Ø 14mm Double clamp 2P= Ø 12mm 4P= Ø 14mm Expansion 1T = Ø 15mm	5 = 6 = 7 = 8=	P = AB0+AB0 $\bar{0}$ PP11/28V B = AB OC 11/28V C = AB $\bar{0}$ OC 11/28V G = AB NPN 11/28V H = AB $\bar{0}$ NPN 11/28V 5 = AB+AB $\bar{0}$ LD5V 6 = AB0+AB0 $\bar{0}$ LD5V 8 = AB+AB $\bar{0}$ LD5/12V 9 = AB0+AB0 $\bar{0}$ LD5/12V K = AB0+AB0 $\bar{0}$ LD 8/24 (out 5V) W = AB0+AB0 $\bar{0}$ Sin-Cos 1Vpp	Cable 3 = Cavo Rad M23 12 P 5 = 9416 Rad SUB-D 9p B = 9415 Rad M12 5p K = M12 Rad M12 8p T = M12 Rad	Ver. Sin-cos S = 5 Volt T = 8/24 Volt		

Option U: outputs levels compatible TTL · Low level output <0.5V · High level output > +VCC-1,9V



	CABLE 2mt 5x014	CABLE 2mt 8x014	DIN 5p 9414	M23 12 p 9416	SUB-D 9p 9415	M12 5p 94M125P	M12 8p 94M128p
0V	White	Black	1	1	1	3	7
+V	Brown	Blue	2	2	2	1	2
A	Green	Brown	3	3	3	2	1
B	Yellow	Beige	4	4	4	4	4
/A		Green		5	5		3
/B		Yellow		6	6		5
0	Gray	Pink	5	7	7	5	6
/0		Violet	5	8	8	5	8